

**WE
CONNECT
PEOPLE WITH
TECHNOLOGY**

TABLE OF CONTENTS

Digital Solutions Company with a Global Presence.....	3	Data & Analytics	13
CX Strategy Solutions.....	4	Design Services.....	14
The Master in the Health Domain.....	5	Platforms and Frameworks	15
Advantages	6	Tools and Platforms we use	16
Healthcare Revenue Cycle Services	7	Infrastructure.....	17
Consulting & Educational Services.....	9	Security Policies.....	18
Offshore Staffing Solution	10	IT Security.....	19
Benefits to our clients	11	Verticals.....	21
We Connect People with Technology.....	12	Who We Serve	22
		Contact us.....	23



DIGITAL SOLUTIONS COMPANY WITH A GLOBAL PRESENCE

Data



Insights



Design



Operation



Culture



Technology

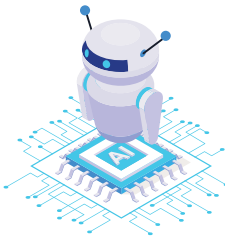

SIX
ELEMENTS



WE WORK AS “ONE TEAM” WITH OUR CUSTOMERS TO CREATE SUPERIOR CX STRATEGY SOLUTIONS



COMPETENCE



Our professionals continuously hone their skills to stay ahead of rapidly changing technologies.

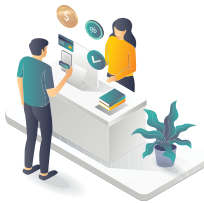

CUSTOMER



Sure, we care about our bottom line, but we value our customers' businesses more.



TURNAROUND



Pena4's workforce hits delivery milestones to support our partners' business mandates.



INTEGRITY



We prioritize integrity engagement to ensure client peace of mind.



QUALITY



We value quality above all else. High-caliber deliverables and industry-leading outcomes are key to our success.

THE MASTER IN THE HEALTH DOMAIN

- Pena4 has developed specialized solutions in the Healthcare, Learning, Sales, & Customer Services domain.
- Pena4 has helped bridge the divide between domain and technology for customers that include world-leading hospitals, clinics, insurance companies, and services companies.
- Pena4 solutions have helped healthcare practitioners access patient health records, track and monitor clinical data, manage hospital business processes and workflows, and help organizations achieve up to 60% savings.
- Over the past few years, Pena4's healthcare team has also developed in-depth expertise in industry standards such as HIPPA, HL7, DICOM & HITRUST.
- Medical Coding & Auditing
- Electronic Health Records
- Healthcare Analytics
- Clinical Data Management
- Patient Monitoring & Communication
- Human Resources & Staffing
- Medical Billing
- Healthcare Operational Assessment
- Decision Support
- Patient Engagement & Assistance
- Virtual Assistants
- Workflow & Document Management
- Customer Services Support
- Healthcare Industry Standards
- IT Support
- Finance Support

**DOMAIN
EXPERTISE
SOLUTIONS
COVERAGE**



ADVANTAGES

Pena4 partners with executives in multiple verticals to streamline efficiencies and cost savings

Virtual Assistants



Pena4's Virtual Assistant capabilities help large organizations, solopreneurs, and individuals access skilled, trained, and professional Virtual Assistants who perform a wide range of tasks

Health Information



Maintain compliance, refine workflows, and meet patient expectations

Human Resources / Staffing



Expend your team with service capabilities without increasing risk to your organization

Revenue Cycle



Support financial viability from claims processed through medical billing

**OUR VIRTUAL RESOURCES
DELIVER SAVINGS FOR
OUR CLIENTS**

**SAVE
UPTO
60%**

HEALTHCARE REVENUE CYCLE SERVICES



Cost Savings



Increased Revenues



24/7 Coverage

Meet consumer need and industry standards

Healthcare organizations are under increasing pressure to continuously improve the patient experience amid diminishing profit margins, declining reimbursements, and elevated operational risks. Pena4's revenue cycle management services deliver customized solutions that drive billing and paying efficiencies, achieve key performance indications, and resolve reimbursement denials and disruptions.

Pena4's comprehensive revenue cycle management capabilities include:

- Comprehensive Outpatient Revenue
- Operational Assessments
- Medical Billing & A/R
- Interim Management
- Education/Training
- Integrity Services
- Medical Coding
- Consulting
- CDM
- CDI

**SUPERIOR
MEDICAL
CODING SINCE
1998**



HEALTHCARE REVENUE CYCLE SERVICES

Reduce Denials and Accelerate Payments

Pena4 serves as an experienced extension of your team. We're not just your go-to medical coding provider – we are your proven medical coding partner. Our outsourced and offshore professionals increase coding capabilities and elevate overall revenue cycle performance.

We support all healthcare settings, including:

- Acute Care Hospitals
- Critical Access Hospitals
- Long-Term Acute Care & Skilled Nursing Facilities
- Ambulatory Surgical Centers
- Medical Practices and Clinics



CONSULTING & EDUCATIONAL SERVICES

Consulting Services

Our team of H.I.M. executives has an average of more than 20 years of hands-on H.I.M. experience with specific focus on:

- Operations and interim management
- Revenue cycle
- Medical coding
 - Assessments
 - Analysis
 - Audits

Our consulting services support revenue capture for healthcare systems, providing data outcomes to make informed decisions and manage processes.

Education Services

Pena4's suite of education programs and resources deliver critical insight, expertise, and industry leadership. Our educational services help H.I.M. professionals achieve medical coding excellence and complete compliance. Pena4's course selection covers vital information, such as:

- Quarterly Review of AHA Coding Clinics
- Quarterly Review of CPT Assistants
- Annual ICD-10 Coding Updates
- Annual CPT Code Updates
- Annual OIG Work Plan
- Comprehensive Documentation
- Hierarchical Condition Categories
- Changes and Updates to CMS IPPS and OPSS systems
- Regulatory and Compliance Issues/Updates



**PROMOTE
A CULTURE OF
MEDICAL CODING
EXCELLENCE**



OFFSHORE STAFFING SOLUTIONS

Pena4's offshore staffing solutions offer our partners access to elite remote talent across multiple verticals, including:

- Administrative
- Finance
- Human Resources
- Information Technology
- Healthcare
- Legal
- Operations
- Customer Support



Advantages to Pena4's Offshore Staffing Services



Cost Reduction

- Pena4 helps you realize true cost savings without compromising quality.
- You gain immediate access to a talented pool of highly educated and experienced resources across multiple disciplines and industries.

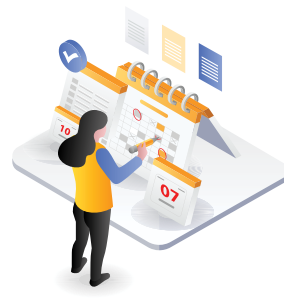

Focus on Priority

- We provide customer service excellence and continuous quality improvement.
- Our customer service professionals develop and maintain relationships with your clients, providing firsthand feedback about their interest in products and services.



Customer Satisfaction

- With your back-office functions outsourced to Pena4, your organization can refocus its attention on areas required to grow the business and revenue.



Latest Technology

OUR OFFSHORE STAFFING SOLUTIONS DELIVER FIVE SIGNIFICANT BENEFITS TO OUR CLIENTS



Quality and Efficiency

The power of a remote workforce continues to grow, allowing organizations to tap into talent on a global scale. Pena4 offers managers immediate access to an elite pool of highly educated and experienced resources across multiple disciplines, specialties, and verticals.



Scale up or Down

Staffing flexibility is critical in any economic climate. Our virtual staffing strategies are customized to meet and evolve with our client's current workforce demand. You can scale up as needed, without the upfront expenses, risk, or losses that come from scaling down.



Meet Customer Demand

Managing support tasks wastes time and keeps you away from your business's core responsibilities. Pena4's offshore staffing solutions equip organizations to outsource their back office job operations, including admin, IT, finance, operations, and legal. Entrusting your manual-intensive functions to Pena4 allows you to meet customer demand and refocus on growing your business and bottom line.



Save Money

Pena4's virtual staffing services are bundled into a set monthly fee. Each payment covers periphery costs such as IT equipment, office space, furniture, support staff, payroll services, employee engagement costs, and more.



Maintain Full Control

When we say we source top-performing talent, we mean it. We only recruit professionals with four-year college degrees. Additionally, the Pena4 model allows clients to train and employ resources who fit into your existing corporate culture. Most importantly, Pena4 adjusts to your practices and technology, ensuring you retain full control of the entire staffing process.

WE CONNECT PEOPLE WITH TECHNOLOGY

Our Innovative Virtual Staffing Solutions Deliver:



Vetted Resource

Access high-performing, talented, and credentialed professionals ready to hit the ground running



Unmatched Flexibility

Grow, scale, and downsize your offshore staffing resources to meet your business needs and client demands



Data Protection

Prioritize data protection in all remote environments for peace-of-mind placements

DATA & ANALYTICS - TRANSFORMING DATA INTO MEANINGFUL INSIGHT



Data Strategy

We partner with your team to help define your data analytics vision and roadmap.



Data Management

We help optimize data collection and storage for performance, security and cost efficiency.



Cloud Native

We are experts in a range of cloud data platforms, and will work to architect the right technology mix.



Visual Analytics

We help analyze big and small data visually to detect trends, patterns and outliers.



Embedded Solutions

Our collaborative, cross-practice teams enable us to create world-class embedded solutions.



Business Intelligence

We are continuously expanding our BI DELTEAI/ML to help solve business science challenges.



DESIGN SERVICES – WE CRAFT INTUITIVE USER EXPERIENCES



User Research & Analysis

We discover the objective, target audiences & their expectations.



Design Strategy

We merge business objectives with creative solutions. DESIGN SERVICES – We Craft Intuitive User Experiences



Wireframe & Prototyping

We create wireframes & prototypes to convey the high-level concept vision and roadmap.



Interactive Design

We design engaging interfaces to ensure enriched experiences.



UI Design & Development

We design and develop business ideas into meaningful user stories.

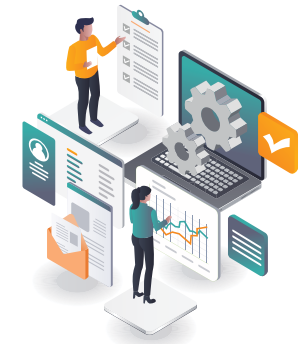

User & Usability Testing

We follow industry standards and use reliable testing tools to deliver the best results.

TECHNOLOGY PLATFORM AND FRAMEWORKS



Mobile Apps



Web Frontend



Web Backend



Databases



Cloud/Integration



TOOLS AND PLATFORMS WE USE

 Microsoft  ORACLE  + a b | e a u  Google Analytics

 mongoDB  kafka  RabbitMQ  PostgreSQL

 MySQL  Azure  Microsoft SQL Server    

 Terraform  kubernetes  ANSIBLE  docker

 Prometheus  GitLab  python™  Azure DevOps 

INFRASTRUCTURE WITH 24/7 COVERAGE

Offices

We firmly believe that having a strong infrastructure support is the base for good business relations. We are strategically located in Vizag & Hyderabad, India (Pena4 Tech); Whitehall, Pennsylvania (Pena4); and Ontario, Canada (H.I.M. ON CALL)

We care for your data privacy as much as we care for ours.

Our servers and systems investments include:

- 300+ computers with the latest configurations that support high-end data entry and processing
- State-of-the-art SOC2 compliant data centers with 99.9% uptime and redundancy
- Latest licensed Antivirus & Firewall protected servers for maximum data security



SECURITY POLICIES

We value security as much as we value privacy. Our security arrangements include:

- HD 1080p CCTV cameras covering the entire flange
- Real-time desktop recording system
- Latest licensed antivirus & firewall protected servers for maximum data security



Confidentiality:

We value your data confidentiality and hence follow stringent security and privacy policies:

Security Policy

- All our employees are bound with strict non-disclosure and non-compete agreements
- Well-protected document storage
- Only authorized entry for employees
- Property well-guarded by professional guards
- No entry allowed for unauthorized items and persons inside the office premises



Privacy Policy

- We assure that none of our employees or representatives will disclose any bid or project details to third parties without proper authorization from the client
- We assure that the complete copyrights of all data in raw, print, digital, processed and finalized form is owned by our clients
- We will destroy or hand over all data pertaining to a completed project once the client has approved



IT SECURITY

Vizag Network Diagram

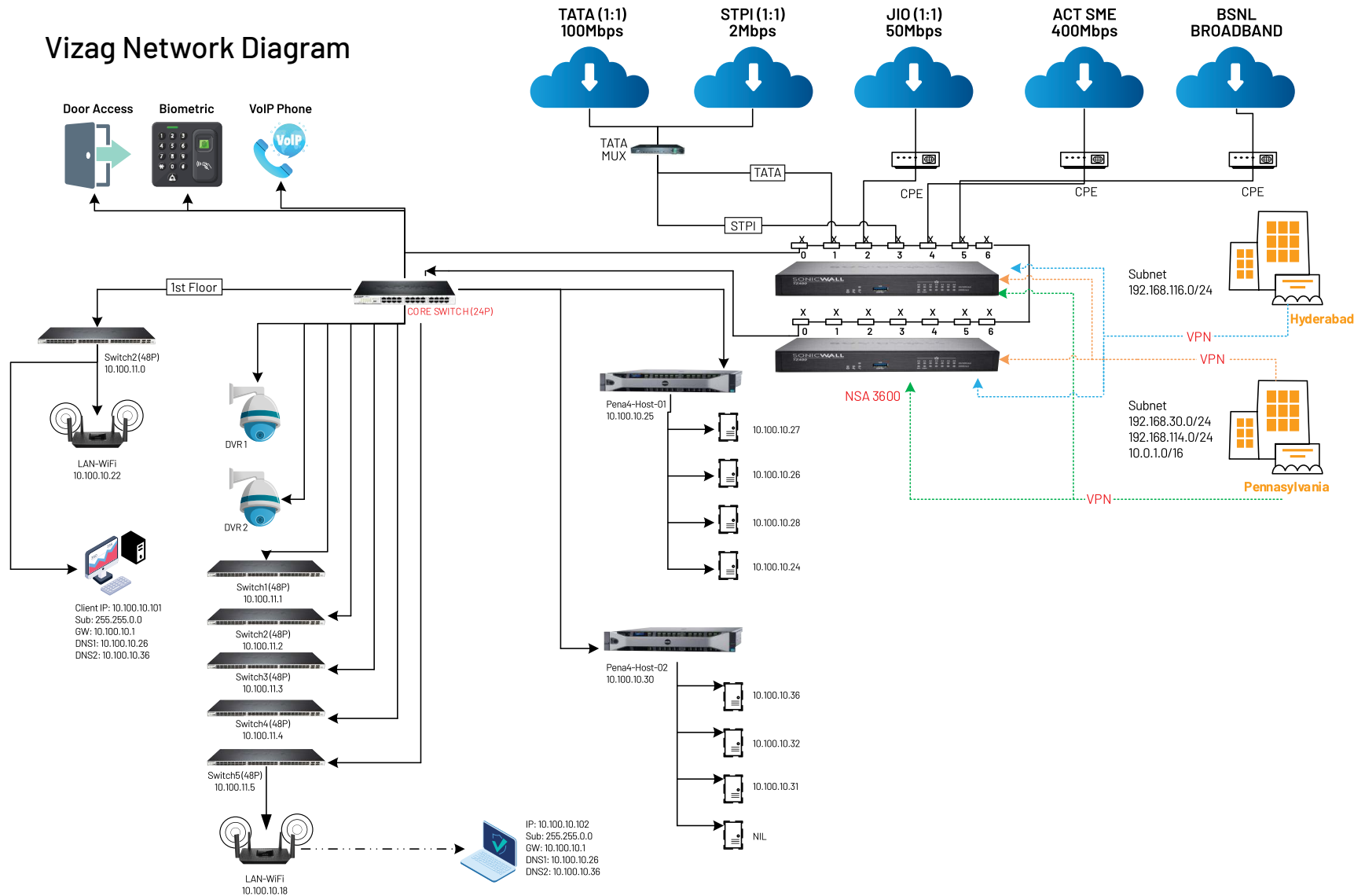

IT SECURITY

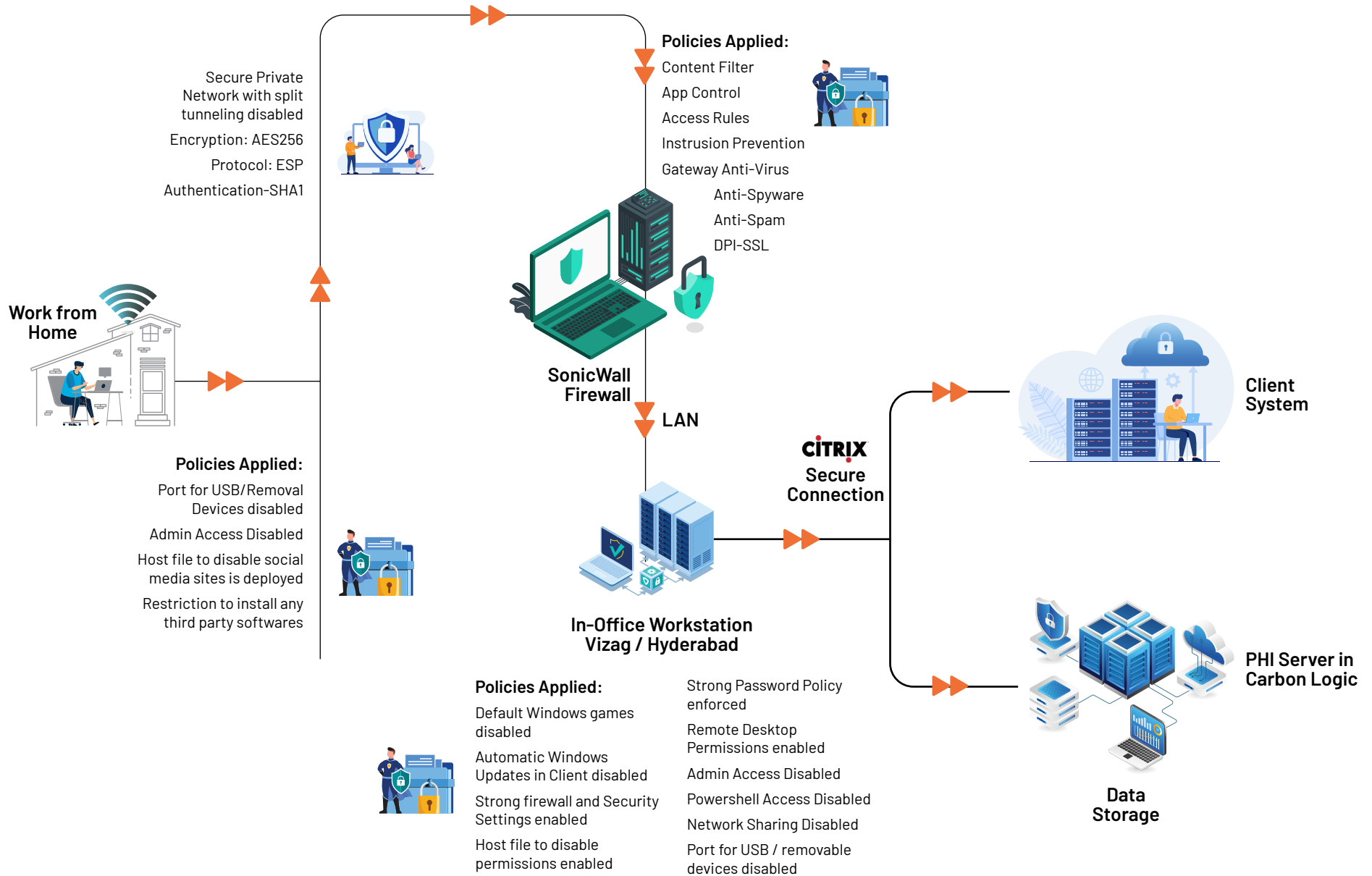

VERTICALS



BFSI



Education

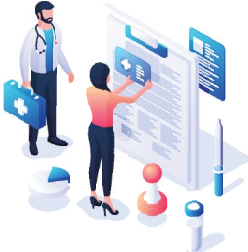

Healthcare

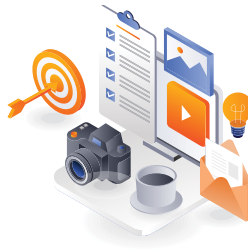

Media

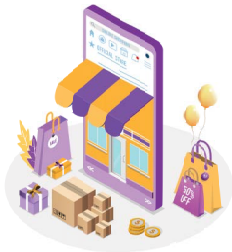

Retail



Automotive

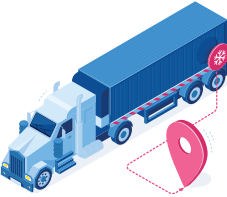

Transportation



Realty

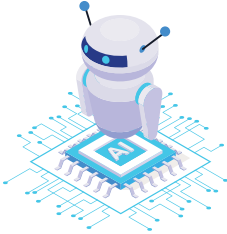

Technology



Tourism



Telecom



E-Commerce



WHO WE SERVE

Lower Costs Drive ROI

Pena4 helps partners across multiple verticals and industries lower hiring risk, expedite talent sourcing, and protect profit margins across every phase of the revenue cycle. Our extensive service strategies make us an ideal resource for:

- Human Resources
- H.I.M. Leaders
- RCM Leaders
- Business Owners
- CFOs
- CEOs
- IT Leaders
- Finance Leaders
- Compliance Leaders

A Dew of Our Clients



CONTACT US

USA Corporate Office

5290 W. Coplay Road
Whitehall, PA
610.435.5724

Canada

7856 Egremont Road,
Watford
Ontario NOM 2S0

India - Hyderabad

No, 52, Road Number 3,
Sri Nagar Colony,
P & T Officers Colony,
Hyderabad, Telangana 500034
040.2354.9429

India - Visakhapatnam

Sector 4, MVP Colony,
Visakhapatnam,
Andhra Pradesh 530017
+91.891.251.3831



Main

610-435-5724



Sales

610-222-6183



E-mail

sales@pena4.com
info@pena4.com



Website

www.pena4.com



